

# 1101 KSS PCB SUPPORT

- Material: UL94V-2 flame rated, UL approved Nylon 66.
- Color: Natural
- Feature: Easy to install / unload by hand, without tool. Pre-drill a hole on P.C board and chassis before usage. Double locking design ensure that once install cannot be removed easily.

UNIT : mm

Item No.	H1	PCB		Chassis		Packing
		hole M1	thickness T1	hole M2	thickness T2	
CS-0305	4.8 (3/16")	4.0	1.8	4.8	2.5	100pcs
CS-0305S	4.8 (3/16")	3.0	2.0	3.0	2.0	
CS-0406	6.4 (1/4")	4.0	1.8	4.8	2.5	
CS-0406S	6.4 (1/4")	4.0	2.3	4.8	2.0	
CS-0610	9.3 (3/8")	4.0	1.8	4.8	2.5	
CS-0813	12.7 (1/2")	4.0	1.8	4.8	2.5	
CS-1016	15.9 (5/8")	4.0	1.8	4.8	2.5	
CS-1219	19.1 (3/4")	4.0	1.8	4.8	2.5	
CS-1422	22.2 (7/8")	4.0	1.8	4.8	2.5	
CS-1625	25.4 (1")	4.0	1.8	4.8	2.5	
CS-1828	28.5 (1 1/8")	4.0	1.8	4.8	2.5	
CS-2236	35 (1 3/8")	4.0	1.8	4.8	2.5	
CS-2236L	35 (1 3/8")	4.8	1.8	4.8	2.5	

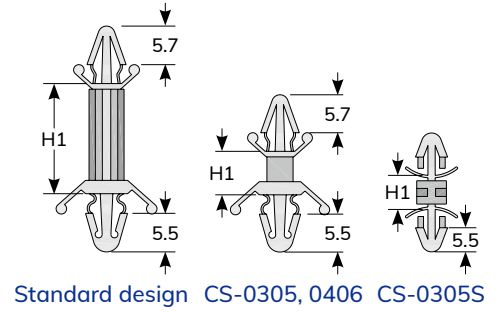

# 1101 KSS PCB SUPPORT

- Material: UL94V-2 flame rated, UL approved Nylon 66.
- Color: Natural

UNIT : mm

Item No.	H1	PCB		Chassis		Packing
		hole M1	thickness T1	hole M2	thickness T2	
CS-0305L	5.4	4.0	2.4	4.0	2.4	100pcs

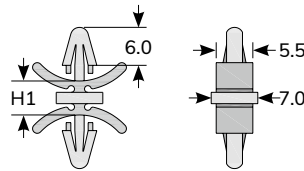

# 1101 KSS PCB SUPPORT

- Material: UL94V-2 flame rated, UL approved Nylon 66.
- Color: Natural

UNIT : mm

Item No.	H1	PCB		Chassis		Packing
		hole M1	thickness T1	hole M2	thickness T2	
MCS-6	6.0	4.0	1.8	4.8	2.0	100pcs
MCS-8	7.8	4.0	1.7	4.8	5.0	
MCS-9	9.4	4.0	1.6	4.8	2.0	
MCS-12	11.5	4.0	1.7	4.8	5.0	
MCS-19	19.0	4.0	2.0	4.8	2.0	

